

# Benchtop Smart Digestion Instrument

## TK-D12

### User Manual

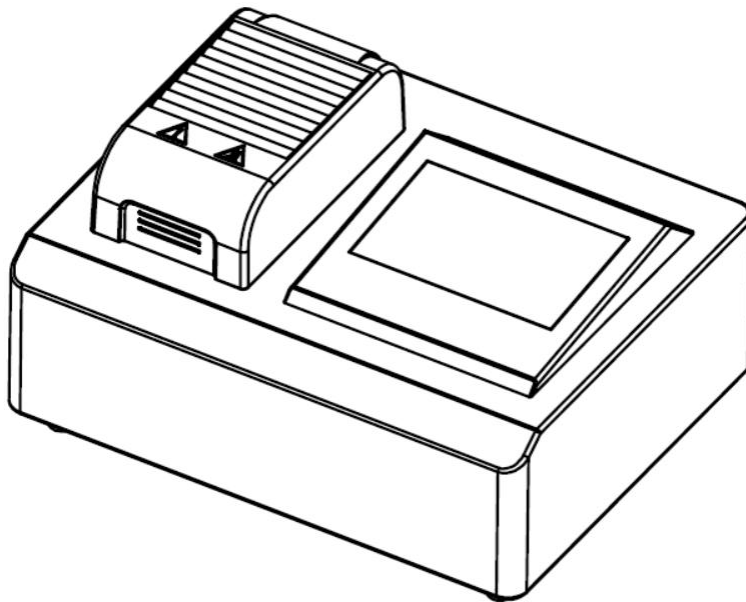

The specifications and information mentioned in this manual are for reference only and are subject to change without notice. Unless otherwise agreed, this manual is for guidance only, and all statements and information herein do not constitute any form of warranty.

# Contents

Friendly Reminder .....	3
1.Product Introduction .....	1
2.Product Features .....	2
3.Technical Specifications .....	3
4.Disclaimer and Warranty .....	4
4.1 Disclaimer .....	4
4.2 Warranty .....	4
5.Instrument Operation .....	5
5.1 Preparation .....	5
5.2 Starting Digestion Program .....	5
5.3 Instrument Settings .....	8
5.4 Help .....	11
6.Packing List .....	13
About Zhongke Tk .....	13

## Friendly Reminder

1. Please read this manual carefully before using the instrument.
2. Do not touch the bottom of the device during heating.
3. Ensure the protective cover is in place before starting, and do not open it during digestion.
4. Do not use digestion tubes or caps that are damaged, leaking, or loose.
5. In case of liquid leakage, immediately turn off the power.
6. Do not place flammable or explosive materials near the instrument.
7. When not in use, keep the protective cover on to prevent dust ingress.
8. Always use a grounded power outlet to ensure safety.

# 1. Product Introduction

The **Benchtop Smart Digestion Instrument** is an advanced 12-well digester designed for water quality testing applications. It is equipped with a 4.3-inch full-color capacitive touch screen, which displays real-time temperature control curves for clear monitoring of temperature changes throughout the digestion process.

Featuring a fast, intelligent digestion system, it supports one-touch operation for multiple water quality testing parameters to meet most user needs, with customizable digestion temperature and time for extended applications. Its user-friendly interface and precise temperature control provide a reliable and efficient solution for laboratory water quality analysis.

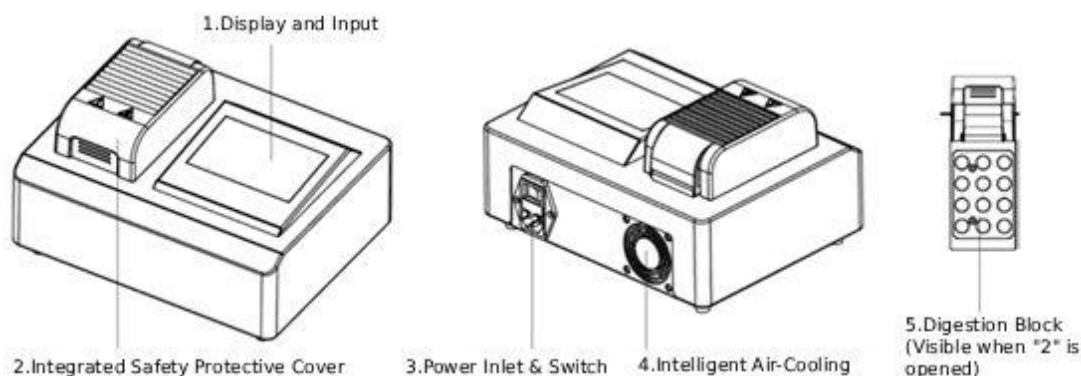

1. **Display & Input:** Used for entering various operation commands and displaying execution results
2. **Integrated Safety Protective Cover:** Provides protection against potential safety hazards caused by tube rupture during digestion.
3. **Power Inlet & Switch:** For connecting the device to power supply and turning the instrument on/off.
4. **Intelligent Air-Cooling System:** Ensures cabinet heat dissipation, extends the service life of electronic components, and protects operator safety.
5. **Digestion Block:** Heating unit designed for 16 mm tubes.

## 2.Product Features

### **Display & Input:**

- 4.3-inch full-color capacitive touch screen with intuitive operation
- Three preset digestion programs (COD<sub>Cr</sub>, TP, TN) with customizable options; Preset programs can be modified using an administrator password.
- Real-time display of temperature curves for precise monitoring during digestion.
- Visual pop-up notifications with audible alerts ensure process monitoring and timely response.
- Real-time display of project type, operating status, current temperature, set time, and remaining time.

### **Control:**

- Thick-film heating technology for long service life and rapid heating.
- Intelligent PID temperature control for precise and stable performance.
- Temperature calibration function to eliminates deviations between displayed and actual sample temperature.

### **Safety:**

- Automatic heating cut-off in case of over-temperature to protect equipment and operator.
- Integrated heat-resistant protective cover for safe observation during digestion.
- Intelligent air-cooling system to maintain suitable internal temperature, prevent burns, and extend electronic component lifespan.

## 3. Technical Specifications

Item	Parameter
Display & Input	4.3-inch full-color capacitive touchscreen
Digestion Capacity	12 tubes
Digestion Volume	0–10 mL
Digestion Hole Size	16.6 mm diameter / 65 mm depth
Temperature Control Mode	Intelligent PID temperature control
Temperature Control Resolution	0.1°C
Temperature Accuracy	±1.5 °C
Temperature Range	0–200°C
Heating Speed	From 25°C to 165°C within 6 minutes
Custom Programs	Supported
Heating Mode	Thick-film heating technology
Overtemperature Protection	Automatic heating cut-off
Protective Cover	High-transparency integrated safety shield
Intelligent cooling	Automatic fan start/stop to prevent accidental burns
Temperature Calibration	Calibrate temperature discrepancy between the sensor and the digestion hole
Completion Prompt	Pop-up notification + buzzer alert
Rated Voltage	AC 110–220V / 50/60Hz
Rated Power	375 W
Dimensions	270 × 214 × 146 mm
Weight	3.55 kg

## 4.Disclaimer and Warranty

### 4.1 Disclaimer

1. The specifications and information mentioned in this manual are for reference only and are subject to change without notice.
2. Please read the safety instructions carefully before using the instrument. The company is not responsible for accidents caused by improper operation.
3. This product is intended for use in professional fields. Operators must have relevant knowledge and skills. Accidents caused by misuse are not covered.

### 4.2 Warranty

1. All products undergo strict inspection before shipment and are covered by a one-year free warranty for quality issues.
2. During the warranty period, if problems arise due to improper operation, unsuitable environment, human error, accidents, or improper storage/transportation, the company may charge repair costs.
3. For out-of-warranty instruments, paid repair and service are available.
4. Warranty does not apply under the following conditions:
  - a. Unauthorized disassembly, modification, or repair.
  - b. Repairs by non-authorized personnel.
  - c. Tampering or breaking of anti-disassembly seals.
  - d. Use of non-original consumables causing malfunctions.
  - e. Products purchased through unauthorized channels.
  - f. Improper use or operation in unsuitable environments.

# 5. Instrument Operation

## 5.1 Preparation

Open the packaging and check whether all instrument accessories are complete and correct. After confirmation, insert the AC power plug into the device's power interface.

Turn on the power switch — the display interface will appear as follows:

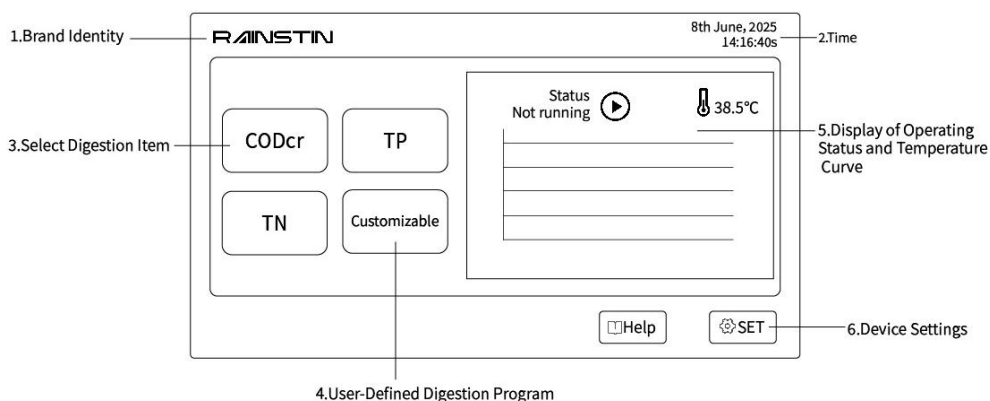

## 5.2 Starting Digestion Program

**5.2.1** Click "3. Digestion Program Selection" as shown in the figure above to choose a preset digestion program (Preset programs: COD, Total Phosphorus, Total Nitrogen).

For example, selecting the "COD" program will display the following interface:

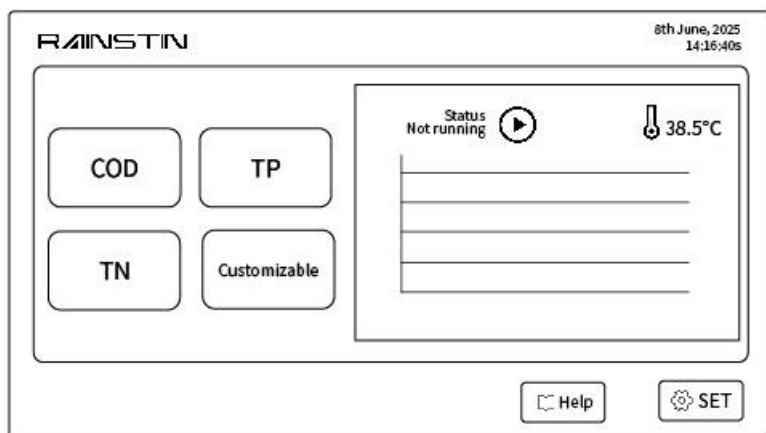

**5.2.2** Press the “▶” button to begin. The instrument will enter the heating state, and the thermometer icon will turn red, with the current temperature displayed in real time beside the icon. Press the “⏸” button to stop heating, as shown in the below figure.

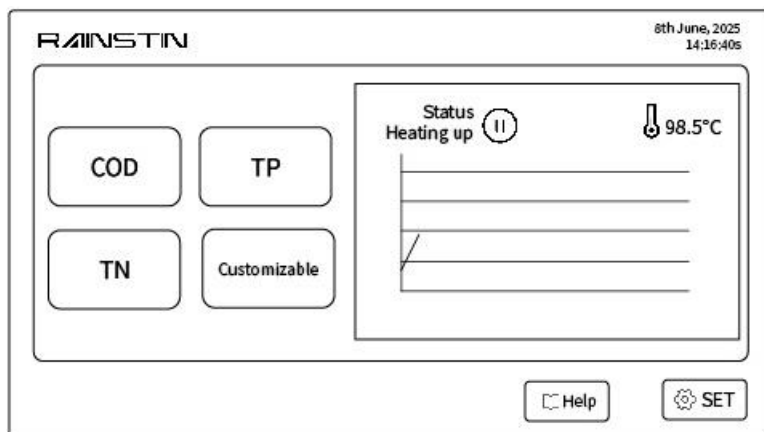

**5.2.3** When the temperature reaches the designated value for the selected digestion program, the instrument will display a popup notification and sound a buzzer. At this time, open the safety shield, place the corresponding reagent into the digestion hole, close the safety shield, and press "Confirm" to start digestion.

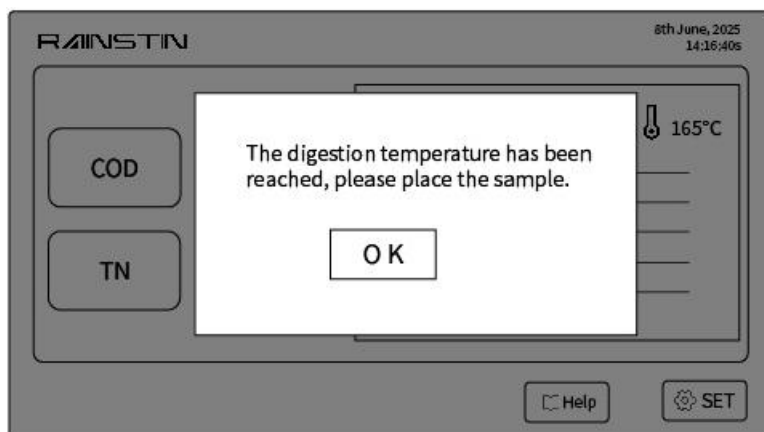

**5.2.4** The digestion program will start a countdown timer.

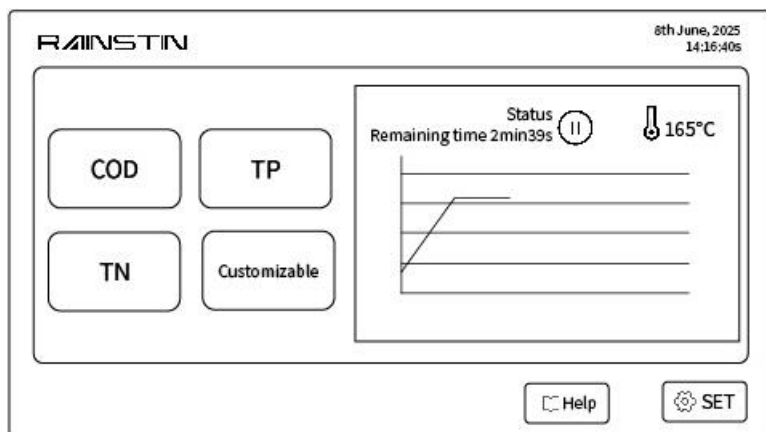

**5.2.5** When the countdown ends, a popup notification will appear with a buzzer alert.

Press "Confirm" to complete the digestion process.



**5.2.6** The display will show "Digestion Complete", and the instrument will begin cooling.

Open the safety shield and allow air circulation for about 3 minutes (to prevent tube rupture caused by thermal shock), then remove and cool the digestion tube.

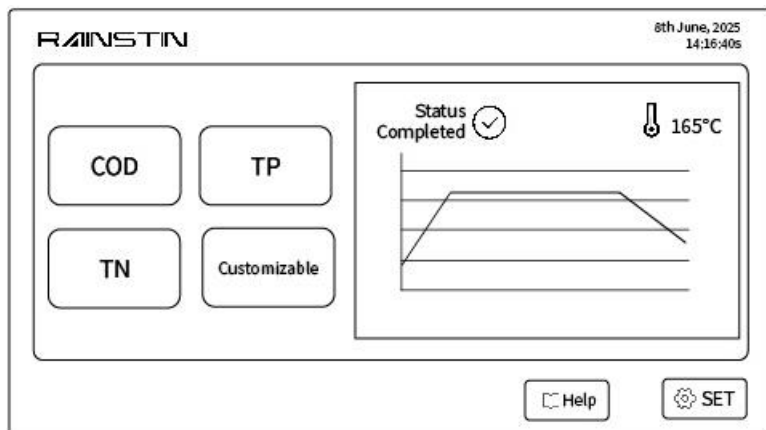

**5.2.7** Other preset digestion programs and custom programs follow the same steps as for COD and will not be repeated.

### 5.2.8 Custom Digestion Program Setup

Click "Custom" to open the setup interface. Enter the required information in the corresponding fields, then press "Select" to choose the desired custom program. If previously saved, select the corresponding program number to load it directly.

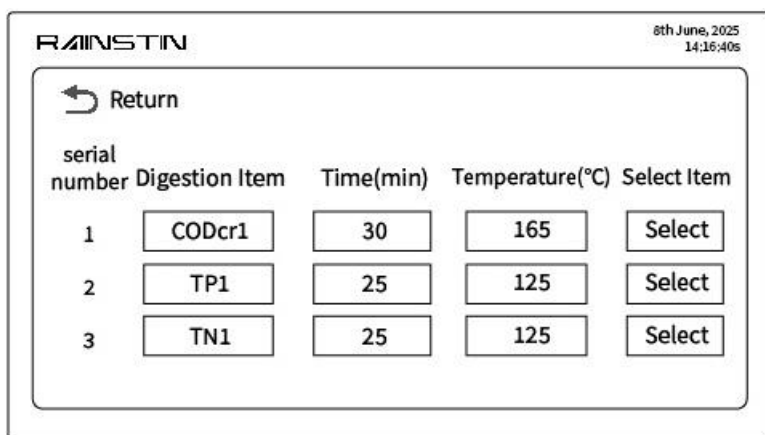

## 5.3 Instrument Settings

**5.3.1** Press the "Settings" button on the main interface to enter the settings menu. Press "Back" to return to the main interface.

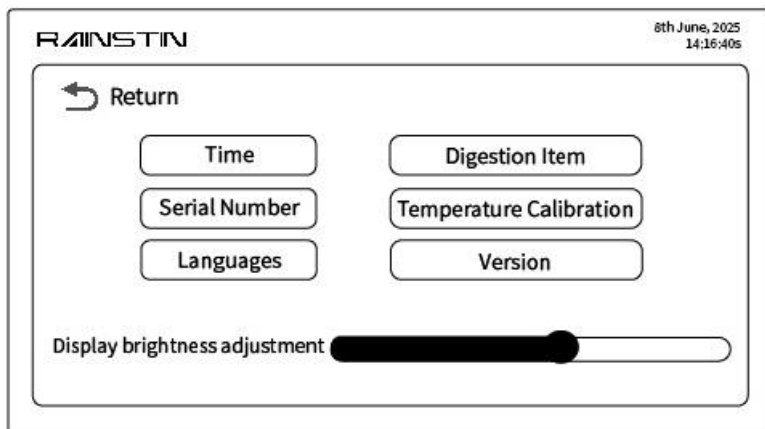

### 5.3.2 Time Setting

Click the corresponding area to input the correct year, month, day, hour, minute and second, then press "Save". Click "Back" to return to the previous menu.

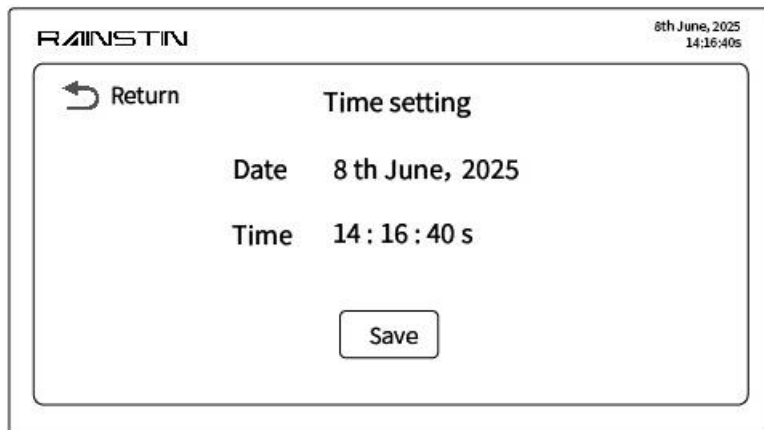

### 5.3.3 Digestion Program Preset

For preset digestion programs, click the corresponding "Program Name", "Temperature Setting", or "Time Setting" to modify. After modification, press "Save", and when the popup appears, enter the password "666666" and press "Confirm" to save the settings.

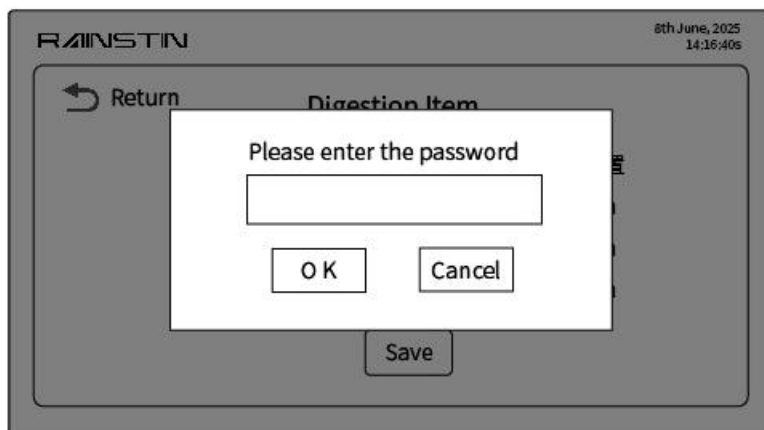
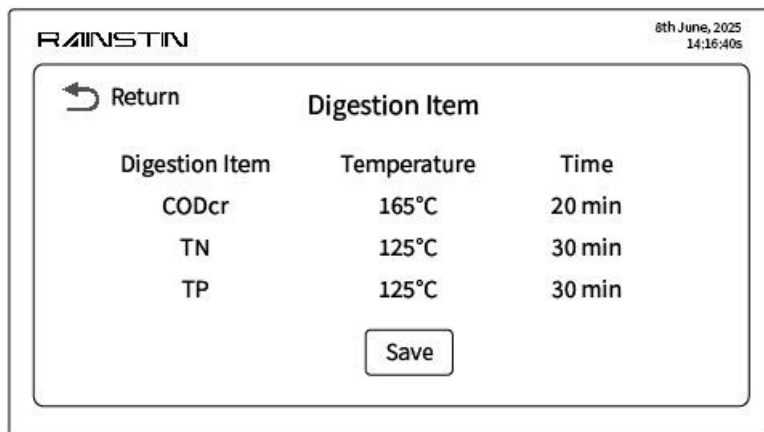

### 5.3.4 Serial Number Setting

Enter the serial number code and press "Confirm" to complete the setting. This serial number is unique and can only be set once. After setting, the serial number can be viewed through this function.

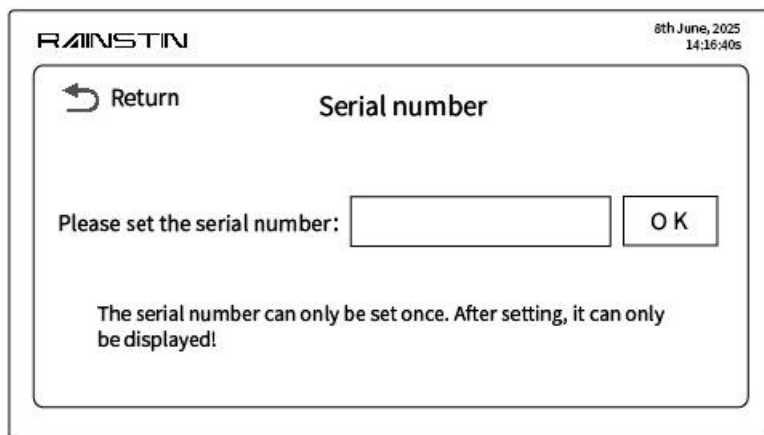

RAINSTIN 8th June, 2025 14:16:40s

Return Serial number

Please set the serial number:  OK

The serial number can only be set once. After setting, it can only be displayed!

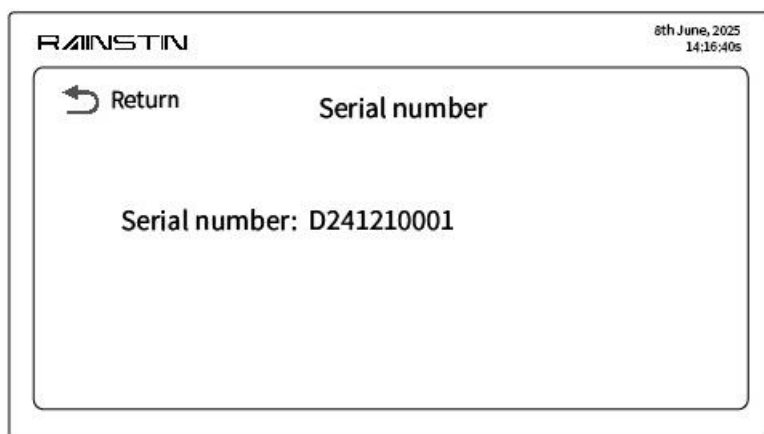

RAINSTIN 8th June, 2025 14:16:40s

Return Serial number

Serial number: D241210001

### 5.3.5 Calibration Setting

This function is for manufacturer personnel only and is not described here.

### 5.3.6 Language Setting

Select different language versions.

### 5.3.7 Version Information

Displays the software and hardware version numbers.

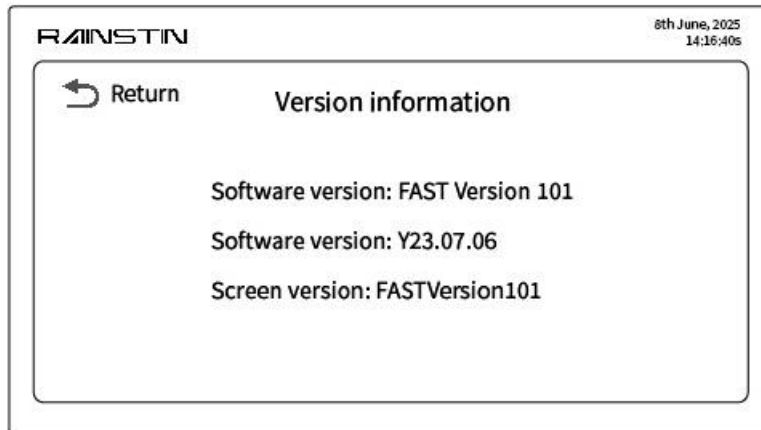

## 5.4 Help

**5.4.1** Click the "Help" button on the main interface to enter the help menu. Press the "Back" button to return to the previous page.

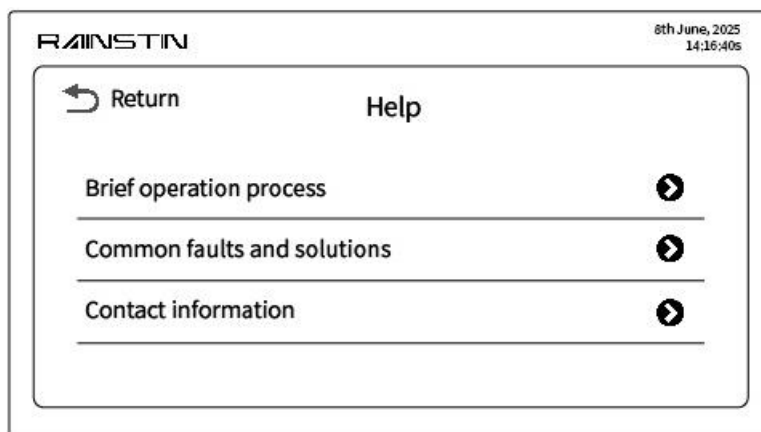

### 5.4.2 Brief Operating Procedure

Provides a simplified guide for basic operation.

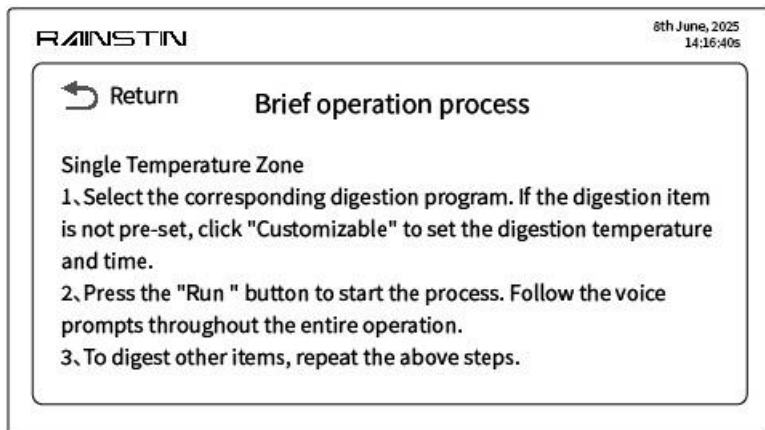

### 5.4.3 Common Issues and Troubleshooting

Lists common malfunctions and their corresponding solutions.

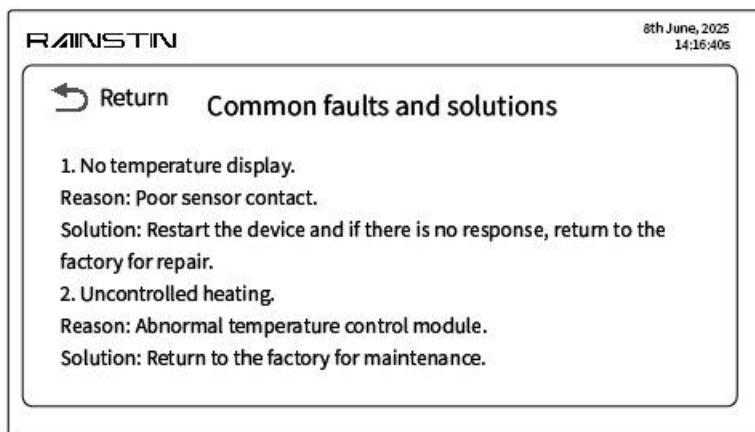

### 5.4.4 Contact Information



## 6.Packing List

Item	Number
Benchtop Digestion Instrument	1
Power Cable	1
User Manual	1
Warranty Card	1

## About Zhongke Tk

Zhongke Tk (Shandong) Intelligent Technology Co., Ltd. was founded in 2015, with its headquarters located in Jinan, Shandong Province. It is a high-tech enterprise specializing in the R&D, production, sales and service of water quality analysis equipment.

The company has a professional R&D team. With profound professional knowledge and rich practical experience, the team members continuously promote the innovation and progress of water quality analysis technology to ensure that the products are always at the advanced level of the industry.

Our products cover a variety of water quality analysis equipment, including hydrogen conductivity meter, dissolved oxygen meter, pH meter, conductivity meter, multi-parameter water quality analyzer, etc. At the same time, the company also provides customized solutions for customers, tailoring suitable water quality analysis equipment and monitoring schemes according to their specific needs.

Adhering to the business philosophy of Technological Innovation, Quality First, Service Supreme, we continuously improve product quality and service level, provides customers with suitable water quality analysis equipment and solutions, and makes greater contributions to the development of the water quality analysis industry.

Address: Room 101-02, Building 22, Jinan Artificial Intelligence Technology Valley (Central District) Project, No.730 Qicai Road, Caishi Street, Licheng District, Jinan City, Shandong Province

Tel: 0531-88908220

Website: [www.tekenwater.com](http://www.tekenwater.com)